

### Design and Implementation of Medical Sleep Stimulator Device

**Samir Shaker Jaifer, Wissam Saadoun Abdel Nabi**

Middle Technical University / Electrical Engineering Technical College

**Prof. Dr. Sadik Kamel Gharkan**

Middle Technical University / Electrical Engineering Technical College

**Sarah Amer Dawood**

Assistant Lecturer, Middle Technical University / Electrical Engineering Technical College

#### Article Information

**Received:** June 02, 2023

**Accepted:** July 01, 2023

**Published:** Aug 18, 2023

#### ABSTRACT

*Medical sleep stimulator device project is a DIY project that aims to create a device that generates a magnetic field similar to the natural magnetic fields found in the earth's environment. The device is meant to be placed under the pillow and has a built-in timer to help induce sleep. The basic idea is that exposure to natural magnetic fields can promote a healthy sleep environment, and the circuit in this project attempts to replicate this effect. However, it's important to note that the scientific evidence supporting the use of magnetic fields to promote sleep is limited, and there are potential health risks associated with prolonged exposure to electromagnetic fields. As with any biomedical device, it's essential to consult with a qualified expert in the field and thoroughly research the safety and efficacy of such devices before attempting to create or use them.*

#### 1. Introduction

Sleeping difficulty, called insomnia, can involve difficulty falling asleep when you first go to bed at night, waking up too early in the morning, and waking up often during the night. The lack of restful sleep can affect your ability to carry out daily responsibilities because you are too tired or have trouble concentrating [1]. All types of insomnia can lead to daytime drowsiness, poor concentration, and the inability to feel refreshed and rested in the morning [2]. Magnetic field associated with the Earth is called Geo-magnetic fields. It is essentially dipolar (i.e., it has two poles, the northern and southern magnetic poles) on the Earth's surface [3]. Away from the surface, the field becomes distorted. Many people experience sleeping well in natural surroundings, into a tent or a wooden hut. This fact is due not only to the healthy atmosphere but also from our unconscious ability to perceive natural Earth's magnetic fields. Our mini project generates this type of Geo-magnetic-fields and our aim is to perceive them: in this manner our brain is surrounded by an ideal environment for a sound sleep.

## **Objectives of the Study**

### **The objectives of the "Design and implementation of medical sleep stimulator device" project likely include:**

1. To explore the relationship between the Earth's magnetic field and sleep quality, and determine the role that magnetic fields play in promoting restful and rejuvenating sleep.
2. To develop a technology or device that can generate similar magnetic fields to those found in natural surroundings and provide an ideal environment for sound sleep [4].
3. To test the effectiveness of the generated magnetic fields in promoting sleep quality and alleviating the symptoms of insomnia.
4. To assess the safety and feasibility of using the generated magnetic fields in real-world settings, and determine any potential side effects or risks associated with the use of the technology [5].
5. To contribute to the scientific understanding of sleep disorders and the factors that influence sleep quality, with the goal of improving treatment and prevention efforts for insomnia.
6. To provide a new and innovative approach to treating insomnia and improve the quality of life for individuals who experience sleep difficulties [6].

### **Helping people sleep by the Earth's magnetic field**

The theoretical background of the "Design and implementation of medical sleep stimulator device" project is based on the idea that the Earth's magnetic field plays a role in promoting healthy and restful sleep. The Earth's magnetic field is essentially dipolar, meaning that it has two poles, the northern and southern magnetic poles, on the Earth's surface. Away from the surface, the field becomes distorted.

Research has shown that many people experience improved sleep quality when they sleep in natural surroundings, such as a tent or a wooden hut. This is believed to be due in part to the healthy atmosphere and in part to our unconscious ability to perceive the natural Earth's magnetic fields. The theory behind the "Design and implementation of medical sleep stimulator device" project is that the generated magnetic fields can mimic the Earth's magnetic field and promote the ideal environment for sound sleep [7].

Additionally, some studies have suggested that exposure to specific types of magnetic fields can have a positive impact on sleep quality and help alleviate the symptoms of insomnia. By generating magnetic fields similar to those found in natural surroundings, the "Design and implementation of medical sleep stimulator device" project aims to harness the therapeutic potential of magnetic fields for the treatment of sleep disorders [8].

1. **Improved sleep:** One potential benefit of using a device like this is that it may help create a more natural sleep environment. Many people find that they sleep better when they are surrounded by natural surroundings, such as in a tent or a wooden hut. By generating a magnetic field that is similar to the Earth's magnetic field, the device may help replicate this natural sleep environment.
2. **Non-invasive:** Unlike medications or other sleep aids, the device is non-invasive and doesn't have the potential for side effects.
3. **Cost-effective:** Since the device is made from common electronic components, it could be a cost-effective solution for people who are looking for a sleep aid .
4. **Limited evidence:** There is currently limited scientific evidence to support the effectiveness of using magnetic fields to promote sleep.

5. Safety concerns: There are safety concerns associated with exposure to electromagnetic fields, and the long-term effects of such exposure are not yet fully understood.
6. DIY approach: Since the device is a DIY project, there is a risk that it may not be constructed correctly, which could lead to safety issues or reduced effectiveness.
7. Individual variation: It's important to note that individual responses to sleep aids vary widely, and what works for one person may not work for another.

### 3.1 Project parts

#### 3.1.1 Resistors

A resistor is a passive two-terminal electrical component that implements electrical resistance as a circuit element. In electronic circuits, resistors are used to reduce current flow, adjust signal levels, to divide voltages, bias active elements, and terminate transmission lines, among other uses. High-power resistors that can dissipate many watts of electrical power as heat may be used as part of motor controls, in power distribution systems, or as test loads for generators. Fixed resistors have resistances that only change slightly with temperature, time or operating voltage. Variable resistors using in this project (R1 = 1K 1/4W Resistors, R2 = 10K 1/4W Resistor, R3 = 10M 1/4W Resistors, R4 = 2M2 1/4W Resistors, R5 = 1K 1/4W Resistors, R6 = 10M 1/4W Resistors, R7 = 2M2 1/4W Resistors, R8 = 4K7 1/4W Resistors, R9 = 4K7 1/4W Resistors).



Figure (3-1) Resistors

#### 3.1.2 Capacitors

A capacitor is a device that stores electrical energy in an electric field by virtue of accumulating electric charges on two close surfaces insulated from each other. It is a passive electronic component with two terminals. The effect of a capacitor is known as capacitance. While some capacitance exists between any two electrical conductors in proximity in a circuit, a capacitor is a component designed to add capacitance to a circuit. We using in this project some capacitors like (C1 = 47 $\mu$ F 25V Electrolytic Capacitors, C2 = 100nF 63V Polyester Capacitor, C3 = 330nF 63V Polyester Capacitors, C4 = 330nF 63V Polyester Capacitors, C5 = 15nF 63V Polyester Capacitors, C6 = 15nF 63V Polyester Capacitors, C7 = 47 $\mu$ F 25V Electrolytic Capacitors).



Figure (3-2) Capacitors

### 3.1.3 Diodes

A diode is a two-terminal electronic component that conducts current primarily in one direction (asymmetric conductance); it has low (ideally zero) resistance in one direction, and high (ideally infinite) resistance in the other. The most common function of a diode is to allow an electric current to pass in one direction (called the diode's forward direction), while blocking it in the opposite direction (the reverse direction). As such, the diode can be viewed as an electronic version of a check valve. This unidirectional behavior is called rectification and is used to convert alternating current (ac) to direct current (dc). As rectifiers, diodes can be used for such tasks as extracting modulation from radio signals in radio receivers. We using in this project diode (1N4148 75V 150mA Diodes).



Figure (3-3) Diodes

### 3.1.4 LED

A light-emitting diode (LED) is a semiconductor device that emits light when current flows through it. Electrons in the semiconductor recombine with electron holes, releasing energy in the form of photons. The color of the light (corresponding to the energy of the photons) is determined by the energy required for electrons to cross the band gap of the semiconductor. White light is obtained by using multiple semiconductors or a layer of light-emitting phosphor on the semiconductor device.



Figure (3-4) LED

### 3.1.5 IC CD4060

The IC 4060 is a CMOS (Complementary Metal-Oxide-Semiconductor) integrated circuit that contains a 14-stage ripple counter and an oscillator. It is commonly used in electronic circuits for applications that require precise timing or frequency generation.

The 14-stage ripple counter consists of a series of flip-flops that divide the input clock signal by powers of 2. The output of each stage is connected to the clock input of the next stage, creating a ripple effect where each stage toggles once for every two pulses from the previous stage. This allows the IC to count up to  $2^{14}$ , or 16,384.

In addition to the counter, the IC 4060 also includes an oscillator circuit that can generate a clock signal for the counter. The oscillator can be configured using an external resistor and capacitor to set the frequency of the output signal [9].

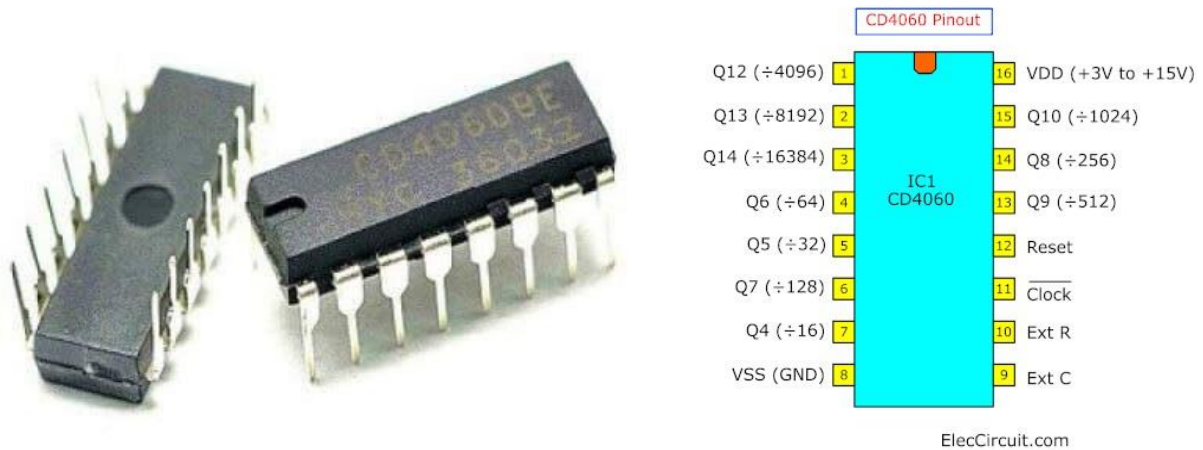

Figure (3-5) IC CD4060

### 3.1.6 IC CD4093

The 4093 IC is a quad 2-input Schmitt NAND gate IC, which means that it contains four separate Schmitt NAND gates, each with two input pins and one output pin. Schmitt NAND gates are digital logic gates that produce an output signal based on the logical AND operation of two input signals, but with the added feature of Schmitt-trigger inputs.

Schmitt-trigger inputs allow the gates to have hysteresis, meaning that the input signal must exceed a certain threshold voltage to switch the output state from high to low, but a lower threshold voltage to switch the output state from low to high. This helps to prevent false triggering of the gate due to noise or other electrical interference.

The 4093 IC is commonly used in digital electronics for applications such as oscillator circuits, pulse generators, and signal conditioning circuits. Because it contains multiple gates in a single package, it can be used to simplify circuit designs and reduce the number of components needed [9].

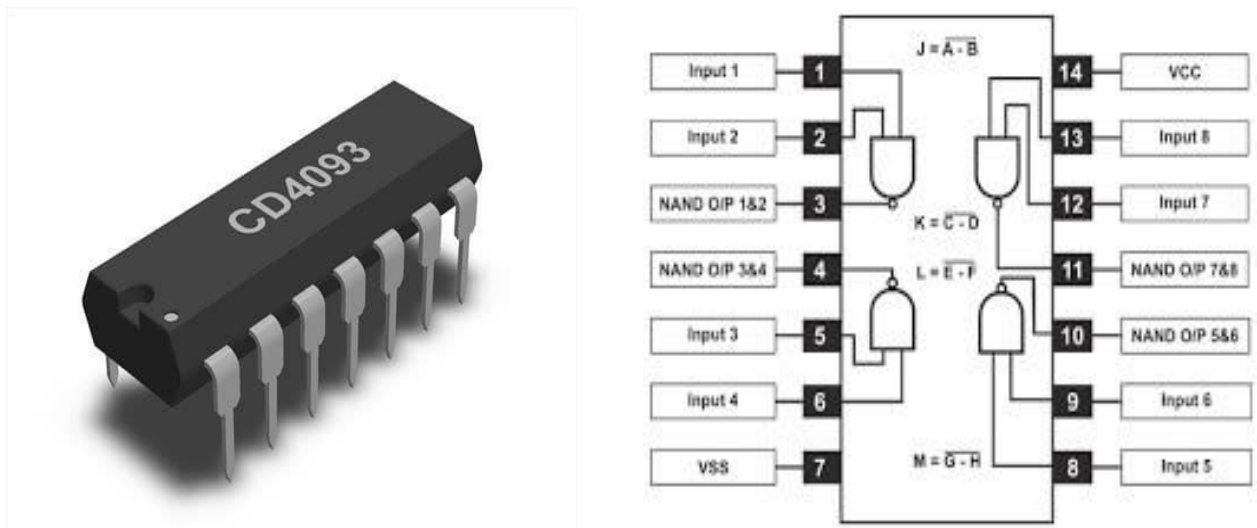

Figure (3-6) IC CD4093

### 3.1.7 PNP Transistor

The BC327 is a PNP (Positive-Negative-Positive) transistor that is commonly used in electronic circuits as a general-purpose amplifier or switch. It has a maximum voltage rating of 45V and a maximum current rating of 800mA. The BC327 is a three-terminal device, with a collector, base,

and emitter. When a positive voltage is applied to the base terminal relative to the emitter, a current flow from the collector to the emitter. The amount of current that flows depends on the voltage applied to the base and the characteristics of the transistor.



Figure (3-7) PNP Transistor

### 3.1.8 Radiator coil

To create the radiator coil, what I did was by getting a 40 mm steel bolt with a 6mm diameter and winding it with a 0.2mm enameled wire for about 600 turns. It takes time to wind the wire due to the wire is very thin and easy to break. So high concentration needed in order to wind it perfectly.



Figure (3-8) Radiator coil

### 3.1.9 SPST pushbutton

A SPST pushbutton is a type of switch that consists of a single-pole, single-throw (SPST) contact mechanism that is activated by pushing a button. When the button is pushed, it makes or breaks an electrical connection between two terminals, allowing or interrupting the flow of current.

SPST pushbuttons are commonly used in electronic circuits for a variety of purposes, such as turning a device on or off, triggering a signal or function, or selecting between two options. They are typically designed for momentary operation, meaning that the connection is only made or broken while the button is being pressed.

The SPST pushbutton is called single-pole because it has one electrical contact, and singlethrow because it only has two positions, on or off. The switch is often represented in circuit diagrams by the symbol of a simple button, with a line indicating the connection between the two terminals.



Figure (3-9) SPST pushbutton

### 3.1.10 Rotary switch 2 poles 4 ways

A 2 poles 4 ways rotary switch is a type of switch that contains two separate circuits or channels, each with four possible connections or positions. The switch is designed to allow the user to select between four different connections for each circuit by rotating the switch to the desired position.

The switch has a rotating knob or lever that can be turned to select between the four possible positions. Each position corresponds to a different connection, allowing the user to switch between different circuits or functions as needed.

The 2 poles 4 ways rotary switch is commonly used in electronic circuits for applications such as audio equipment, lighting controls, and motor control. For example, the switch could be used to select between different speakers or audio sources in a sound system, or to control the direction of rotation for a motor.



Figure (3-10) Rotary switch 2 poles 4 ways

### 3.1.11 Battery 9V

A 9V battery is a small, rectangular-shaped battery commonly used in portable electronic devices such as remote controls, smoke detectors, and small audio devices. It is called a 9V battery because it provides a nominal voltage of 9 volts when fully charged.

9V batteries are typically made up of six cylindrical or rectangular cells connected in series inside a single housing. The cells are usually made of carbon-zinc or alkaline chemistry and are designed to provide a stable voltage over a relatively long period of time.

The terminals of a 9V battery are usually located at one end of the housing, with a positive and negative terminal for connection to an electronic device. The battery is typically designed to be easily replaceable, with a Snap-On or slide-in connector that allows it to be quickly and easily removed and replaced as needed.

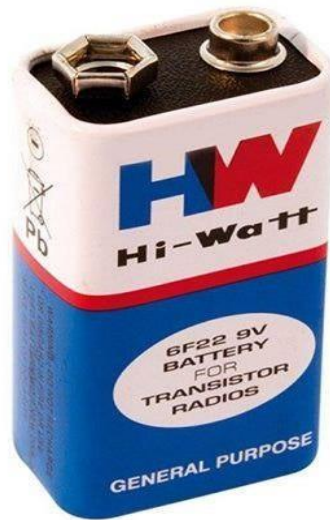

Figure (3-11) Battery 9V

### 3.2 Circuit Diagram for project

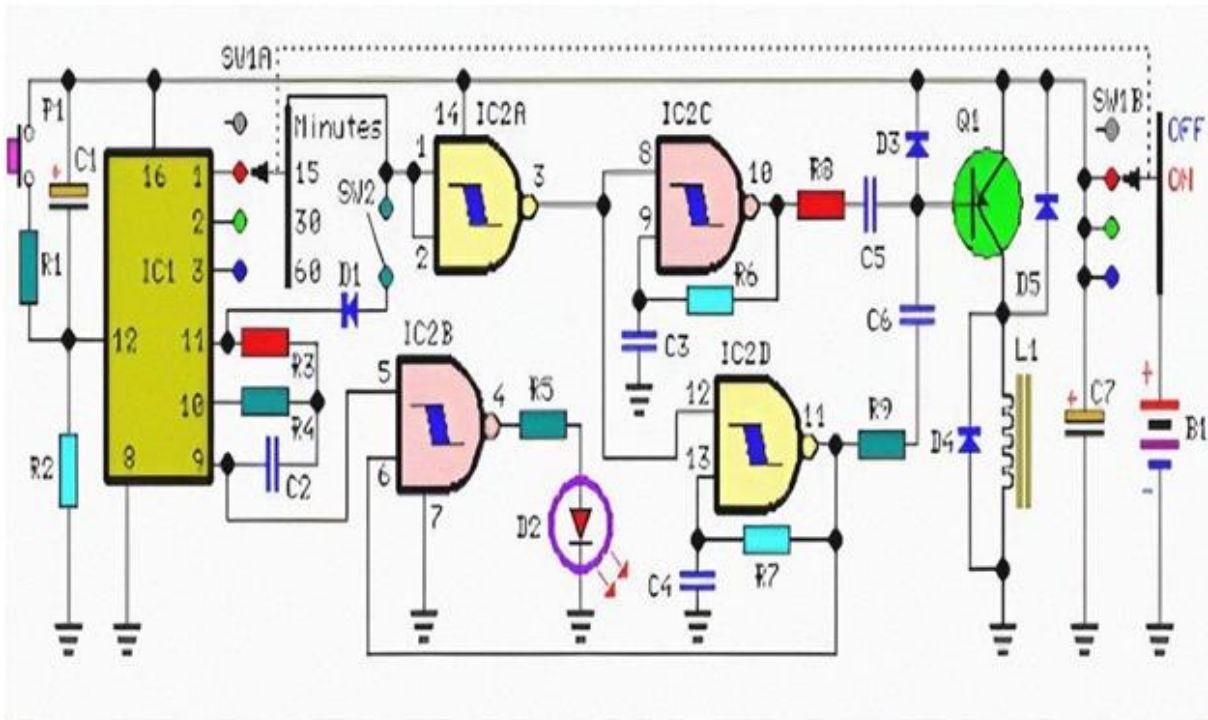

Figure (3-12) Circuit Diagram

### 3.3 Procedures required for use this project:

1. Select a timing option by means of the rotary switch SW1.
2. Choose 15, 30- or 60-minutes operation.
3. Select “Stop” or “Alternate” mode operation by means of SW2.
4. With SW2 closed (Stop mode operation) the electromagnetic radiation stops after the preset time is elapsed.
5. With SW2 opened (Alternate mode operation) the device operates for the pre-set time, then pauses for the same amount of time: this cycle repeats indefinitely.
6. Place the unit under the pillow and sleep like a log.
7. To reset a cycle press P1 pushbutton.

Notes:

L1 is obtained by winding randomly 600 turns of 0.2 mm, enameled wire on a 6 mm, diameter, 40 mm, long, steel bolt and secure the winding with insulating tape.

Mean current drawing is about 7mA, decreasing to less than 4mA during pauses when in Alternate mode operation.

Battery life can be dramatically increased omitting LED D2 and its associated resistor R5.

Use a plastic box to enclose the circuit: metal cases can severely limit electromagnetic radiation.

### 4.1 Results

#### Circuit Operation:

IC2C and IC2D generate two square waves at about 1.2 and 5 Hz respectively. These waveforms are converted into 60 $\mu$ S pulses at the same frequencies by means of C5 & C6 and mixed at Q1 Base. This transistor drives the Radiator coil with a scalar series of pulses of 60 $\mu$ S length and 9V amplitude. IC1, IC2A & IC2B form the timer section.

C1 & R2 provide auto-reset of IC1 at switch-on. The internal oscillator of IC1 drives the 14-stage ripple counter and, after about 15 minutes, output pin 1 goes high. Pin 3 of IC2A goes low and stops IC2C & IC2D oscillation. If SW2 is left open (Alternate mode operation), after 15 minutes pin 1 of IC1 goes low, pin 3 of IC2A goes high and oscillators are enabled again.

If SW2 is closed (Stop mode operation), the first-time output pin 1 of IC1 goes high, the internal oscillator of the IC is disabled by means of D1. Therefore, the circuit remains off until a reset pulse is applied to pin 12 by means of P1 or when the whole device is switched-off and then restarted. The same thing occurs when SW1 is switched on 30- or 60-minutes positions, obviously changing time length [10].

#### IC2B drives pilot LED D2 which operates in the following three modes:

1. flashes quickly and almost randomly when the Radiator coil is driven
2. flashes somewhat slowly and regularly when the Radiator coil is pausing during the Alternate
3. mode operation
4. is off when the circuit auto-stops (Stop mode operation)

## 4.2 Circuit Diagram and Waveforms using Proteus simulation

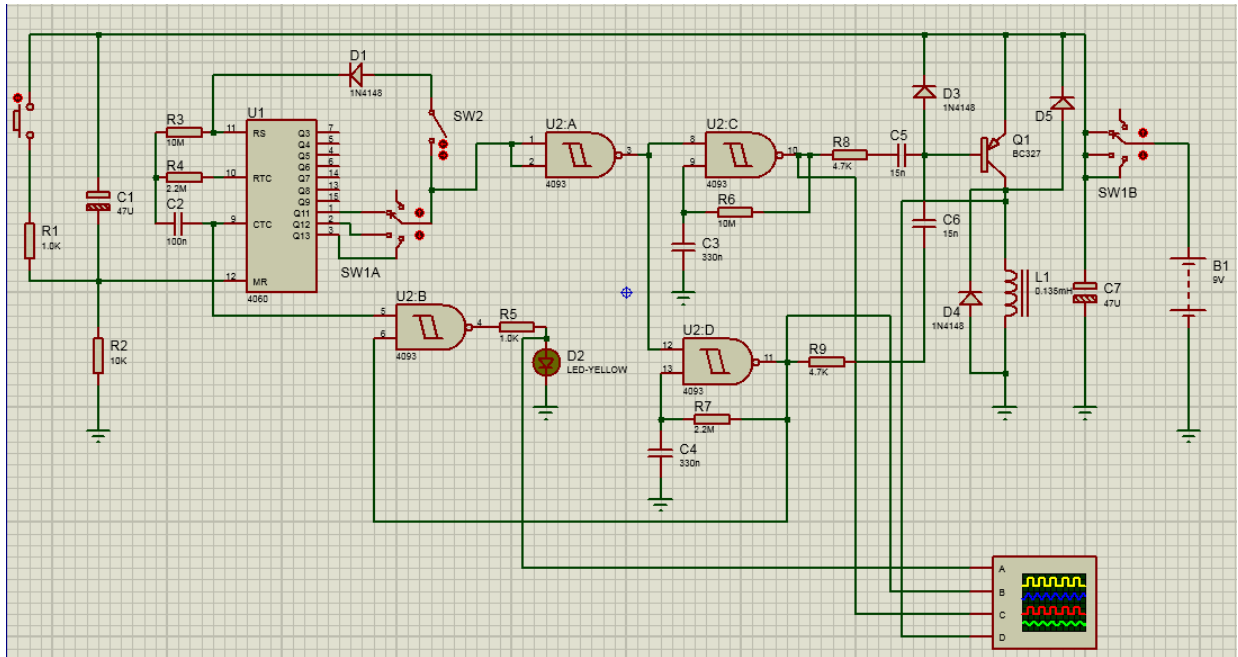

Figure (4-1) Circuit Diagram in proteus simulation

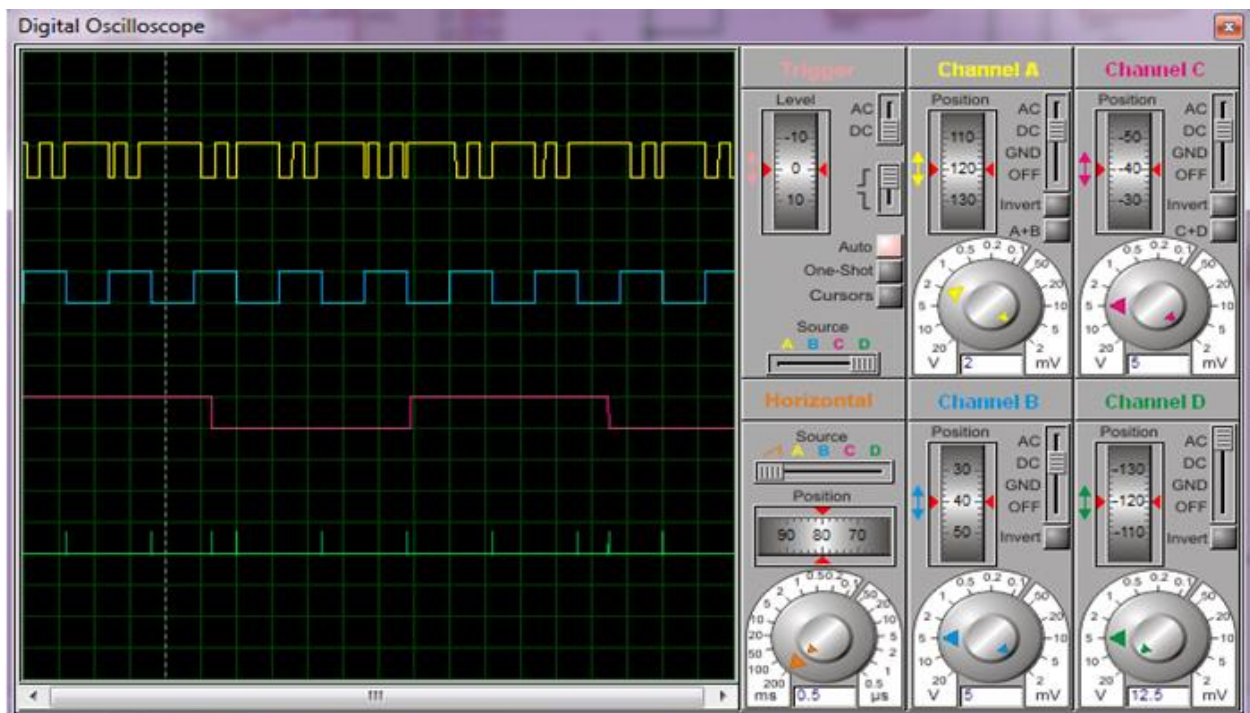

Figure (4-1) Waveforms in proteus simulation

## 4.3 Discussion

This project involves creating a device that generates a geo-magnetic field to help induce sleep. While the idea of using magnetic fields to promote sleep has been around for some time, the scientific evidence to support its effectiveness is limited.

### Benefits:

1. Improved sleep: One potential benefit of using a device like this is that it may help create a more natural sleep environment. Many people find that they sleep better when they are surrounded by natural surroundings, such as in a tent or a wooden hut. By generating a

magnetic field that is similar to the Earth's magnetic field, the device may help replicate this natural sleep environment.

2. **Non-invasive:** Unlike medications or other sleep aids, the device is non-invasive and doesn't have the potential for side effects.
3. **Cost-effective:** Since the device is made from common electronic components, it could be a cost-effective solution for people who are looking for a sleep aid [11].

#### **Limitations:**

1. **Limited evidence:** There is currently limited scientific evidence to support the effectiveness of using magnetic fields to promote sleep.
2. **Safety concerns:** There are safety concerns associated with exposure to electromagnetic fields, and the long-term effects of such exposure are not yet fully understood.
3. **DIY approach:** Since the device is a DIY project, there is a risk that it may not be constructed correctly, which could lead to safety issues or reduced effectiveness.
4. **Individual variation:** It's important to note that individual responses to sleep aids vary widely, and what works for one person may not work for another.

#### **5.1 Conclusions**

1. The project involves creating a device that generates a geo-magnetic field to promote sleep.  
2- The device is meant to be placed under the pillow and has a built-in timer.
2. There is limited scientific evidence to support the effectiveness of using magnetic fields to promote sleep.
3. There are potential health risks associated with exposure to electromagnetic fields, which are a subject of ongoing research and debate.
4. Creating biomedical devices requires expertise in various fields, including engineering, biology, and safety and regulatory compliance.

#### **5.2 Recommendations:**

1. **Consult with experts in the field:** Before attempting to create a biomedical device, it's essential to consult with experts in various fields, such as engineering, biology, and safety and regulatory compliance. They can help ensure the safety, efficacy, and compliance for project.
2. **Conduct thorough research:** It's important to conduct thorough research on the scientific literature, regulatory requirements, and potential risks and benefits associated with the use of magnetic fields for promoting sleep.
3. **Prioritize safety:** Safety should be the top priority in any biomedical project. Make sure to follow all safety guidelines and regulations and consult with experts to ensure that device is safe for use.
4. **Test and evaluate device:** Once you have created device, it's important to test and evaluate its effectiveness and safety in a controlled environment. This can help to identify any potential issues and refine the design.
5. **Consider alternative approaches:** If you are unable to create a safe and effective biomedical device, consider alternative approaches for promoting sleep, such as changes in sleep hygiene or the use of other sleep aids that have been shown to be effective and safe.

## REFERENCES

1. Daniel J. Taylor, Kenneth L. Lichstein, H. Heith Durrence, Brant W. Reidel, Andrew J. Bush, Epidemiology of Insomnia, Depression, and Anxiety.
2. [http://en.wikipedia.org/wiki/Neuroscience\\_of\\_sleep](http://en.wikipedia.org/wiki/Neuroscience_of_sleep).
3. Andrew A. Marino, Erik Nilsen, Andrew L. Chesson Jr., Clifton Frilot, Effect of lowfrequency magnetic fields on brain electrical activity in human subjects.
4. Andrew A. Marino, Erik Nilsen, Andrew L. Chesson Jr., Clifton Frilot, Consistent magneticfield induced dynamical changes in rabbit brain activity detected by recurrence quantification analysis.
5. Z. Zhang et al., "Reduction in time-to-sleep through EEG based brain state detection and audio stimulation," 2015 37th Annual International Conference of the IEEE Engineering in Medicine and Biology Society (EMBC), Milan, 2015, pp. 8050-8053. doi: 10.1109/EMBC.2015.7320261.
6. Z. Zhang et al., "Automatic sleep onset detection using single EEG sensor," 2014 36th Annual International Conference of the IEEE Engineering in Medicine and Biology Society, Chicago, IL, 2014, pp.2265-2268.
7. F. Jie, W. Tiecheng, Y. Yan, B. H. Duc and L. Xiaoping, "A magnetic field projector for deep brain modulation," Neural Engineering (NER), 2013 6th International IEEE/EMBS Conference on, San Diego,CA, 2013, pp. 1214-1217.
8. Y. Morita, K. Yamaguchi, K. Ashida, R. Ikeura and K. Yokoyama, "Verification of sleepinducing effect by excitation apparatus simulating mother's embrace and rocking motion," Robot Motion and Control (RoMoCo), 2013 9th Workshop on, Kuslin, 2013, pp. 80-85. doi: 10.1109/ RoMoCo.2013.6614588.
9. Datasheet of 4060 IC and 4093 IC provided by: <http://www.datasheetcatalog.com/>.
10. Marshall L, Helgadóttir H, Mölle M, Born J., Boosting slow oscillations during sleep potentiates memory (University of Lübeck, Department of Neuroendocrinology).
11. Md. MahadiHasan, Sourav Dev, ArifAhammad, International Journal of Engineering Research & Technology, Vol.2 - Issue 9 (September - 2013), [www.ijert.org](http://www.ijert.org).